

OPTIONAL METHOD OF PROOF LOAD.
"X" AND "Y" ARE SUPPORTING POINTS FOR SIDE LOAD.

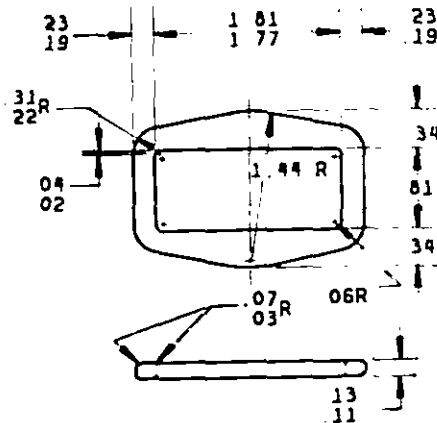

ADAPTER ASSEMBLY

FRAME

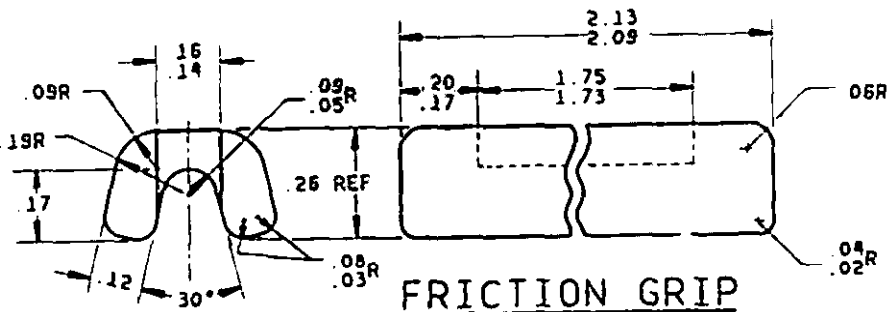

FRICITION GRIP

DASH NO.
-1
-2
-3

NOTES:

- MATERIAL: GRIP- STEEL, MIL-S-5626, OR MIL-S-16729, OR MIL-S-6049.
FRAME- STEEL, MIL-S-16728 OR MIL-S-16729.
- HEAT TREATMENT: AFTER ASSEMBLY, 170,000 TO 190,000 LBS/SQ. IN. TENSILE STRENGTH IN ACCORDANCE WITH MIL-H-6875.
- SURFACE ROUGHNESS SHALL BE $\sqrt{125}$ MAX. IN ACCORDANCE WITH ANSI B46.1.
- ADAPTER SHALL BE SUBJECTED TO A 500 POUND PROOF LOAD AS INDICATED BY ARROWS IN ACCORDANCE WITH THE PROCUREMENT SPECIFICATION.
- FINISH- AFTER ASSEMBLY AND HEAT TREATMENT:
 - 1. CADMIUM PLATE, CLASS I, TYPE I, QQ-P-416.
 - 2. CADMIUM PLATE, CLASS I, TYPE II, QQ-P-416. } *
 - 3. COATING, IMMERSION ZINC FLAKE/ CHROMATE DISPERSION PER MIL-C-87115, CLASS 3.

* (AS AN ALTERNATE, THE COATING FOR THE -3 FINISH MAY BE USED FOR THE -1 & -2 FINISHES.)
- DIMENSIONS IN INCHES. EXCEPT AS OTHERWISE SPECIFIED HEREIN, TOLERANCES ± 0.03 , ANGLES $\pm 2^\circ$.
- FOR DESIGN FEATURE PURPOSES, THIS STANDARD TAKES PRECEDENCE OVER PROCUREMENT DOCUMENTS REFERENCED HEREIN.
- REFERENCED DOCUMENTS SHALL BE OF THE ISSUE IN EFFECT ON DATE OF INVITATION FOR BID.
- PART NUMBER: THE MS PART NUMBER CONSISTS OF THE MS NUMBER PLUS THE DASH NUMBER.
EXAMPLE: MS 70101-1.

© REDRAWN, REVISED NOTES 1 & 5, ADDED NOTE 9, OPT. PROOF LOAD, & SHEET 2.

USER ACTIVITIES

REVERSE ACTIVITIES USAF-02

AMSC N/A
RESTRICTION STATEMENT: Approved for public release; distribution is unlimited.
This document is approved for use by all Departments and Agencies of the Department of Defense.
Instructions for all use requirements and design applications and for reproduction use shall be made from this document.

P. A. ARMY-6L Other Code NAVY-A5 USAF-99	INTERNATIONAL INTEREST	TITLE ADAPTER, REVERSIBLE, QUICK FIT, 500 LB; 1-3/4 INCH	MILITARY STANDARD MS 70101
PROCUREMENT SPECIFICATION MIL-H-7195	SUPERSEDES	QMC DVG 11-1-205 NPU DVG 598380	SHEET 1 OF 2

REVISED 30 APRIL 1968 APPROVED

USER ACTIVITIES:

REVIEWER ACTIVITIES: USAF-82

This military standard is approved for use by all Departments and Agencies of the Department of Defense. Selection for all new engineering and design applications and for repetitive use shall be made from this document.

FED. SUP CLASS
5340

END ITEM EXAMINATION DIMENSION - FUNCTION TEST

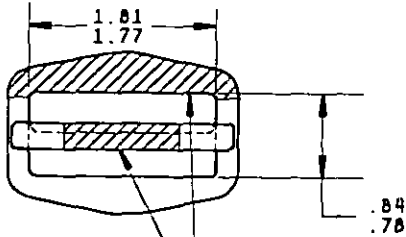

HARDNESS TEST TO BE PERFORMED IN SHADED AREAS (ON FRAME & PIN).

NOTES:

CRITICAL FUNCTIONAL TEST: GRIP BAR SHALL MOVE FREELY.

CRITICAL DIMENSIONS: AS SHOWN.

© THIS SHEET ADDED.

APPROVED
REVISED © 30 APRIL 1986

P. A. ARMY-GL Other Code	INTERNATIONAL INTEREST	TITLE ADAPTER, REVERSIBLE, QUICK FIT, 500 LB; 1-3/4 INCH	MILITARY STANDARD	
			MS 70101	
PROCUREMENT SPECIFICATION MIL-H-7195	SUPERSEDES: QMC DWG 11-1-205 NPU DWG 598380		SHEET	2 OF 2